

XI. *Description of a new Tide-Gauge, constructed by Mr. T. G. BUNT, and erected on the eastern bank of the river Avon, in front of the Hotwell House, Bristol, 1837. Communicated by the Rev. WILLIAM WHEWELL, M.A. F.R.S. &c.*

Received March 15,—Read March 22, 1838.

THE principal parts of this machine are :

- A, an eight-day clock, which turns
- B, a vertical cylinder, revolving once in twenty-four hours :
- C, a wheel, to which an alternate motion is communicated by
- D, a float rising and falling with the tide, and connected with C by the wire E, passing over the pulley F, and kept constantly strained by the counterpoise G :
- H, a small drum on the same axis with C, which, by a suspending wire, communicates one-eighteenth of the vertical motion of the float to
- I, a bar carrying a pencil, K, which marks a curve on the cylinder B, so as to show the time and height of high water.

The above will convey a general notion of the machine and its use ; but it will be necessary to enter more into detail.

a (figs. 1, 2 and 3) is a strong oak frame secured to the quay wall ; b is a mahogany frame resting on the arms c c, which are supported by the pillars d d ; e is a bracket resting on a pillar f, and sustaining the cylinder B. The lower pivot of the cylinder has its bearing in a small cylindrical plug *b* (fig. 5.), which may be lowered by a screw and a winch, as seen in the figure, so as to disengage, first the upper pivot, and afterwards the lower one, when the cylinder may be drawn out of its place, being made to slide forwards horizontally on the two cross pieces *a a*.

The pencil K, fig. 4, is inserted into a tube soldered to the brass bar *d*. This bar moves without shake, on a long axis *e*, so as not to require side friction to guide it, while it is pressed forwards against the cylinder by the weight and bent lever L ; *f* is a small bolt for holding back the pencil, when necessary, by thrusting it into the stud *g* ; *h* is a nut and screw for adjusting the height of the pencil to the scale. The pencil is guided vertically by a mahogany bar N, fig. 3, having a groove in its edge for receiving the ivory wheel *o*, which is pressed gently against N by the brass rod P, slightly curved towards the pencil, to produce the requisite pressure. Q Q are two other brass rods (or tubes) for guiding the lower end of the pencil bar I, by means of the cross guide R, fitted loosely on the rods. The guide N is adjusted, or may be drawn out, by means of a notch in the board T, which supports it, the top of the bar being held by a tenon. The pillar d is represented as broken off, for the purpose of

MDCCCXXXVIII.

2 K

showing the guides N and Q. The outer support S, fig. 2, of the axis of the wheel C, is also removed.

The cylinder, which is 24 inches in length and 48 in circumference, is composed of mahogany staves 2 inches in width and 1 inch in thickness. It has two heads and a diaphragm, also of mahogany, into which every stave is screwed by a screw at each end, and another in the middle. A strong iron axis passes through the whole length of the cylinder, which revolves on a rounded steel pivot screwed into the lower end of the axis. The surface is a white enamel, fit for receiving the mark of a pencil. On the top is screwed a brass wheel, equal in diameter to the cylinder, and divided into 360 teeth. A two-hour pinion (*p*) of thirty teeth, at the bottom of the clock face, causes this wheel to perform one revolution in twenty-four hours. This pinion, together with the rest of the train, is seen in fig. 6.

The clock is of a superior kind, and larger size than ordinary, having a fir pendulum rod and a dead-beat escapement. It goes exceedingly well, and appears to suffer no derangement in the regularity of its motion from the incumbrance of the cylinder. This, however, is very trifling, a weight of half an ounce being sufficient to overcome it. The pallets may be detached from the train by lifting a latch behind the clock, and drawing them backwards. This arrangement is required from its being necessary to *fix* the hands so that they cannot, as in other clocks, be made to slide without carrying the train along with them. The pinion which drives the cylinder may be detached from it by pulling it forwards, so as to permit the cylinder to be turned freely round.

Although the workmanship of the clock is good, yet, from inequalities in the teeth of the wheels, the cylinder is not moved round through exactly equal spaces in equal times. To prevent error from this cause, the hours and minutes marked round the top of the cylinder, were divided out in the following manner. The cylinder being connected with the clock, but the pallets and pendulum detached from it, the hands, which now move rapidly forward, are brought to the instant of 0^h 0^m, where they are held fast while a vertical line is drawn on the cylinder, by the pencil moving between the guides. The hands are then moved forwards 20 minutes at a time, and a line drawn on the cylinder at each of these periods, until the whole circumference has been divided into 72 spaces. These are afterwards subdivided to every 5 minutes. Another necessary precaution is, to *mark* a tooth of the large wheel on the cylinder, and the *two corresponding teeth* of the small wheel which turns it, and in the same manner to mark all the wheels in the train, so that whenever the clock is taken to pieces to be cleaned or repaired, the wheels may be put together again, with the teeth in exactly the same relative positions as before. By this means, a source of considerable error is entirely obviated.

The scale of height may be obtained, by marking the outside of the trunk containing the float into feet, and watching the ascent of the surface of the tide until it reaches one of the lower marks, when a mark must be instantly made with the pencil

on the cylinder. Successive marks, as the tide and pencil continue to ascend, at length complete the scale. A better and more expeditious method is by accurately measuring and dividing the circumference of the large float wheel, and then marking the cylinder with the pencil as it is wound up, by moving the wheel round and bringing its divisions successively up to a fixed index.

The pencil curves may be either received on the enamelled surface of the cylinder, or they may be taken off on paper, very correctly, in the following manner. The sheet having been wrapped round the cylinder, and expanded by rubbing it all over with a wet sponge, is then pasted together at the ends, and secured in its place, either with drawing pins, or with elastic bands, as shown in the drawing; after which it soon becomes quite tight, and the curves may be taken and read off on the paper with nearly as much accuracy as on the enamel itself, with the additional advantage of their being preserved.

The times and heights are read off by means of the vertical scale M, which is held at the two extremities by notches cut in the frame, and may be pushed into contact with the cylinder. The large wheel being detached from the clock, and a short chord-line drawn under the summit of each of the curves and bisected, the point of bisection is turned round to the edge of the scale, the upper end of which shows the time of high water, amongst the divisions of hours and minutes on the cylinder. The height is read off by noticing where the summit of the curve falls amongst the graduations of the scale. Thus in fig. 2. the curve in contact with the scale indicates the time of high water to be 0^h 40^m P.M. and the height 32 feet 11 inches.

The float is of pine, well saturated with oil, and has hitherto preserved sufficient buoyancy. It is without friction rollers, which it is better to dispense with when its motion is very nearly vertical. The trunk is of cast iron $\frac{7}{8}$ ths of an inch in thickness, being in a situation where considerable strength was required. At the back of the trunk is a stout wooden plank, and both together are firmly secured with nuts, and bolts inserted with lead into the quay-wall. The joints are caulked, and the water enters through a moveable shutter in the bottom, by an aperture of about $\frac{1}{10}$ th of the sectional area of the trunk. This was found after many trials to be the best size for preventing unsteady motion of the float, which is now almost entirely removed; a rapid undulation being communicated to it when the aperture was made much larger, and a slow but very considerable oscillation when it was much less.

Fig. 2.

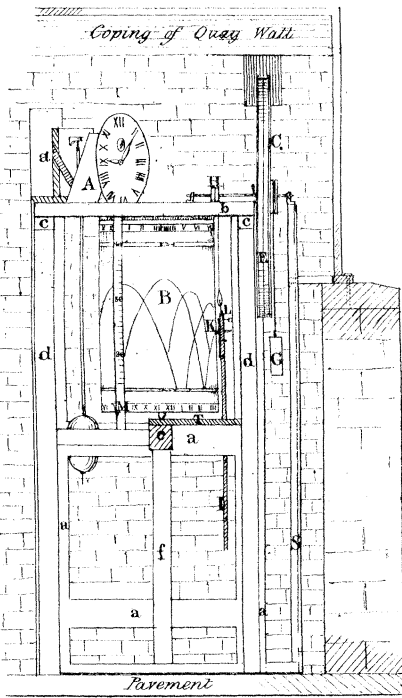

Fig. 3.

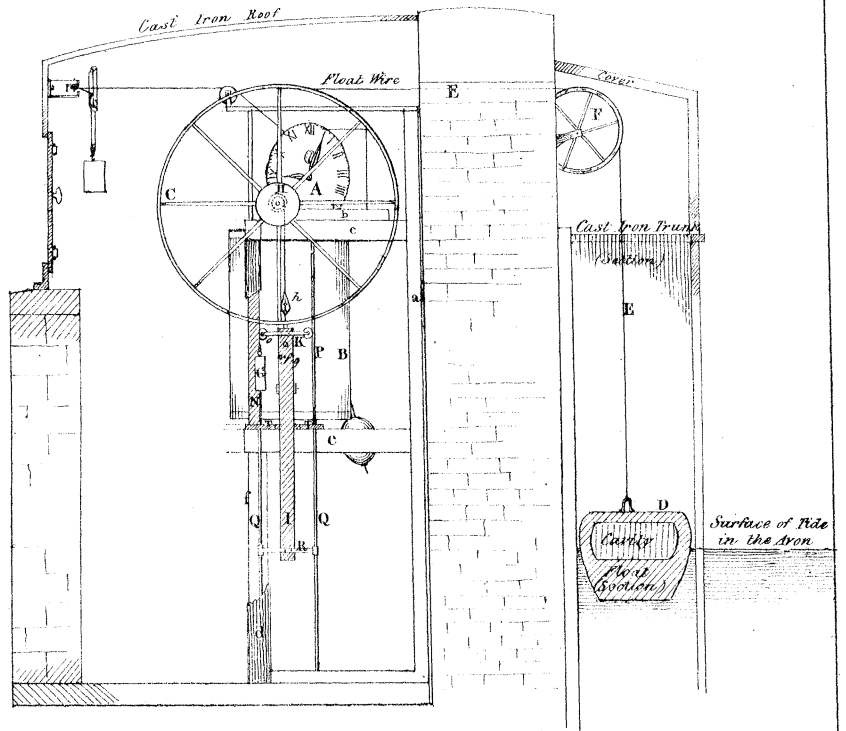

Fig. 1.

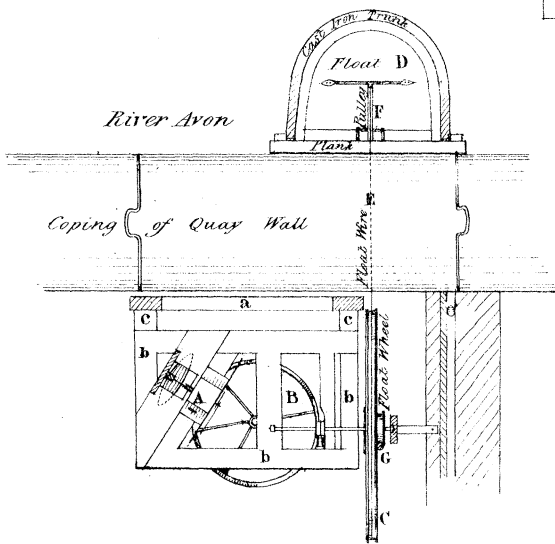

Fig. 6.

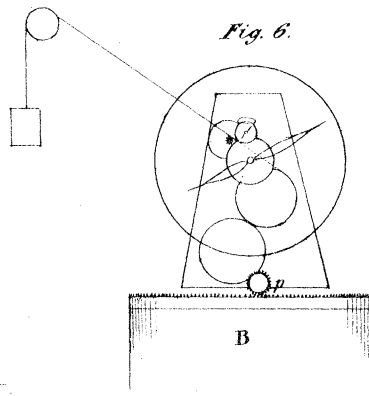

Fig. 5.

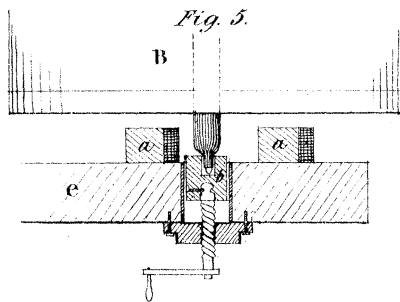
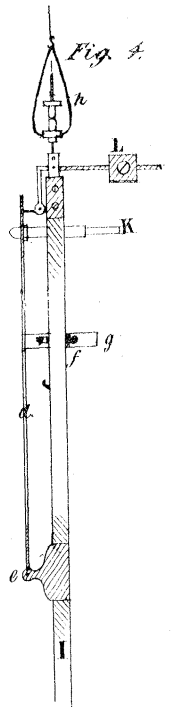

Fig. 4.



Scale of feet & inches

